

Iron Gate Valves PN16/235PSI/Class125

Outside Screw and Yoke, Solid Wedge, Bronze Seat
Design to BS5150 and MSS SP-70
Flange Dimension to EN1092-2, ANSI B16.1 Class 125

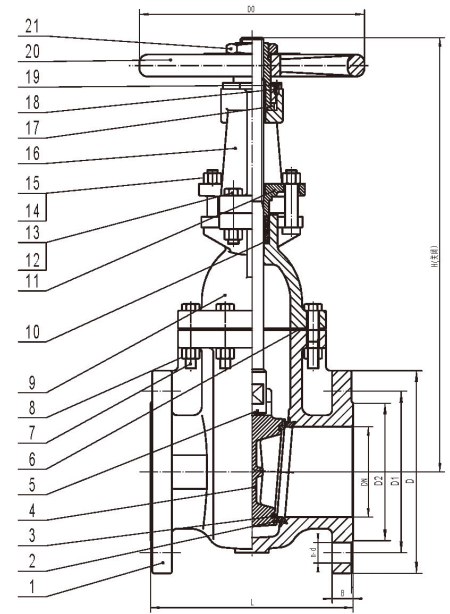

MG670-R
2" - 24"



Hydraulic Pressure Test	
Body	2.4Mpa/24Bar
Seat	1.76Mpa/17.6Bar

Pressure Ratings	
1.0 Mpa at 180°C	
1.6 Mpa at -10°C-120°C	

Materials List

No	Part	Specification	BS EN	ASTM
1	Body	Cast Iron	BSEN 1561	A126 Class B
2	Seat Sealing Ring	Cast Bronze	1982 CC491K	B62
3	Disc Sealing Ring	Cast Bronze	1982 CC491K	B62
4	Disc	Cast Iron	BSEN 1561	A126 Class B
5	Stem	Brass	12164 CW603N	B16
6	Gasket	Graphite	--	--
7	Bolt	Steel	BSEN 10087	Steel A307
8	Nut	Steel	BSEN 10087	Steel A307
9	Bonnet	Cast Iron	BSEN 1561	A126 Class B
10	Packing	Graphite	--	--
11	Seal Gland	Ductile Iron	BSEN 1563	A536 65-45-12
12	Bolt	Steel	BSEN 10087	Steel A307
13	Nut	Steel	BSEN 10087	Steel A307
14	Gland Bolt	Steel	BSEN 10087	Steel A307
15	Gland Nut	Steel	BSEN 10087	Steel A307
16	Yoke	Cast Iron	BSEN 1561	A126 Class B
17	Yoke Bushing	Brass	12164 CW603N	B16
18	Screw	Steel	BSEN 10087	Steel A307
19	Yoke Nut	Cast Iron	BSEN 1561	A126 Class B
20	Handwheel	Cast Iron	BSEN 1561	A126 Class B
21	Handwheel Nut	Steel	BSEN 10087	Steel A307

Dimensions-Weights

mm	50	65	80	100	125	150	200	250	300	350	400	450	500	600
In	2	2½	3	4	5	6	8	10	12	14	16	18	20	24
L	178	190	203	229	254	267	292	330	356	381	406	432	457	508
H	311	347	384	490	541	656	778	933	1102	1259	1395	1560	1708	1990
D	165	185	200	220	250	285	340	405	460	520	580	640	715	840
D1	125	145	160	180	210	240	295	355	410	470	525	585	650	770
D2	99	118	132	156	184	211	266	319	370	429	480	548	609	720
D0	178	178	200	254	300	300	348	400	457	560	560	610	610	765
B	20	20	22	24	26	26	30	32	32	36	38	40	42	48
n-d	4-19	4-19	8-19	8-19	8-19	8-23	12-23	12-28	12-28	16-28	16-31	20-31	20-34	20-37
Weight	Lbs	38	51	62	110	154	203	284	459	637	838	1014	1484	2701
	Kg	17	23	28	50	70	92	129	208	289	380	460	673	1225